

# Vector Frame Light Box R-02

## VF-LB-R-02

Vector Frame™ fabric light boxes feature durable 100mm aluminum extrusion frames, push-fit backlit fabric graphics and LED edge lighting. Single and double-sided graphic options are available. LED lights come adhered to the frame, making set-up as simple as assembling the frame, applying the push-fit graphics and plugging in the electrical cord!

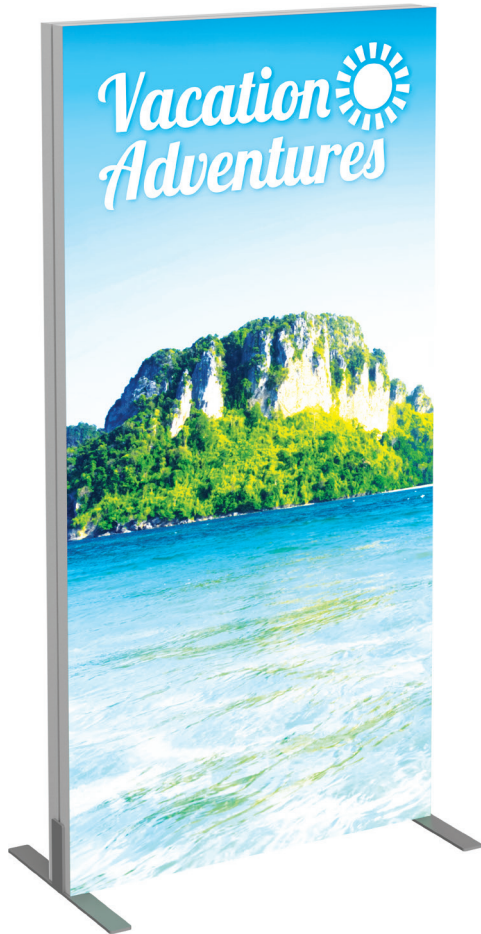

## features and benefits

- 100mm silver extrusion frame
- LED lighting top and bottom
- Single or double-sided SEG dye-sublimated fabric graphics
- Easy assembly
- Comes packaged in one OCH wheeled molded case for transport or storage
- Lifetime hardware warranty against manufacturer defects

## dimensions

Hardware	Graphic
<p>Assembled unit:                      36.3" w x 71.12" h x 19.685" d                      922.02mm(w) x 1806.448mm(h) x 499.999mm(d)</p>	<p>Total visual area:                      35.31" w x 70.75" h                      897mm(w) x 1797mm(h)</p> <p>Refer to related graphic templates for more information</p>
<p>Shipping</p>	
<p>Shipping dimensions:                      1 OCH case: 50" l x 29" h x 12" d                      1270mm(l) x 737mm(h) x 305mm(d)</p> <p>Approximate shipping weight (entire kit):                      61.51 lbs / 27.9 kgs</p>	

## additional information

Graphic material:  
Dye-sublimated fabric

We are continually improving and modifying our product range and reserve the right to vary the specifications without prior notice. All dimensions and weights quoted are approximate and we accept no responsibility for variance. E&OE. See Graphic Templates for graphic bleed specifications.

Parts Included:

Code	Qty	Description
F29	x2	900MM (35.43") LENGTH OF PHFC4 EXTRUSION - WITH MITRE CUT FOR CB9 BOTH SIDES
VF-LB-R-02-G	x2	900MM (35.43")W X 1800MM (70.87")H FABRIC GRAPHIC W/FEC-2 ALL SIDES
LED-WHT-DB-300	x4	300MM (11.81") LENGTH LED LIGHTS FOR DIRECTIONAL BACKLIT
CB9	x4	CB9 CORNER BRACKET
SW-FOOT	x2	VECTOR FRAME SUPPORT FOOT
F62	x3	900MM (35.43") LENGTH OF PHFC4 EXTRUSION - WITH MITRE CUT FOR CB9 ONE END - IB2 LOCK HOLES ONE END
F63	x1	900MM (35.43") LENGTH OF PHFC4 EXTRUSION - WITH MITRE CUT FOR CB9 ONE END - IB2 LOCK HOLE ONE END WITH WIRE CHASE HOLE
IB2	x2	PH INLINE CONNECTOR
WME-800	x2	800MM (31.5") GREY RPVC WIRE MANAGEMENT EXTRUSION

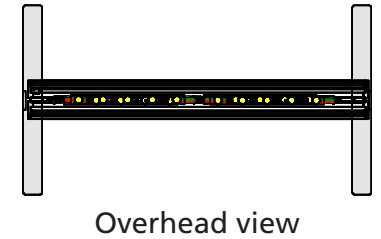
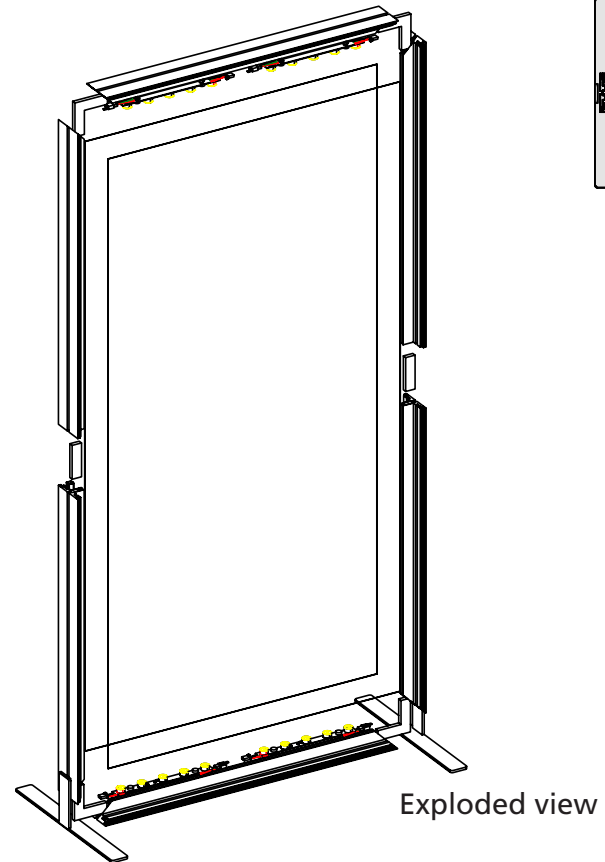
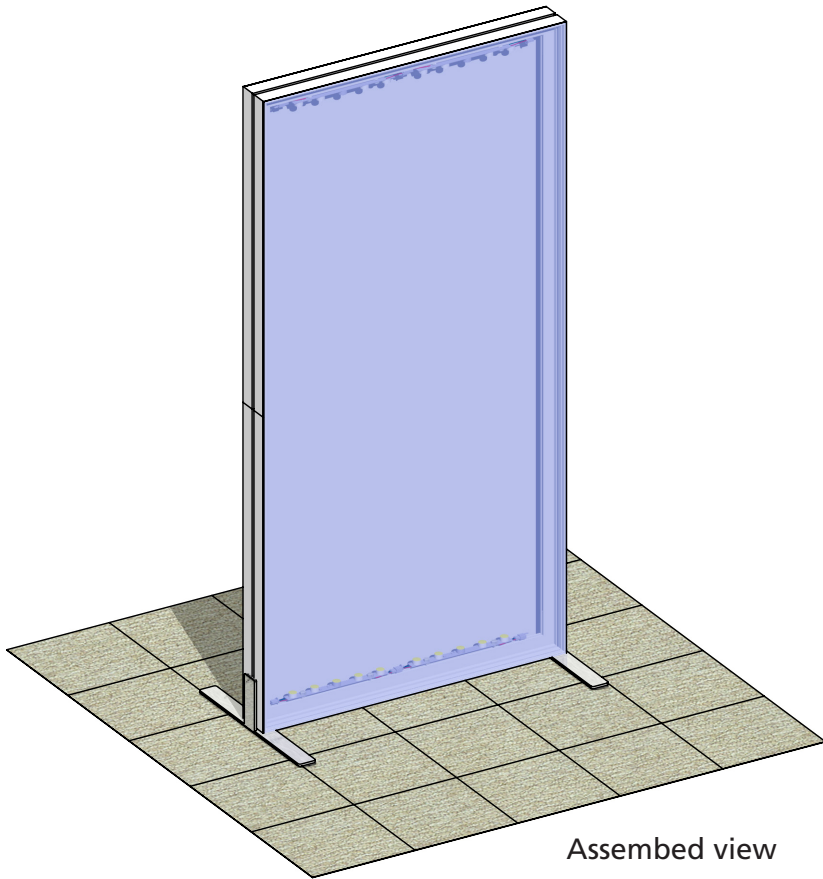

## Step 1: Assemble Frame

Arrange pieces on the floor as shown in the diagram below. Assemble frame by sliding CB9's into corners of the F29, F62 and F63. When locking be sure to turn each cam a little bit and then go back and tighten to the proper tension. Take care to turn locks only half a turn. Lights come adhered to the F29s. Ensure lighting strips on top and bottom are connected.

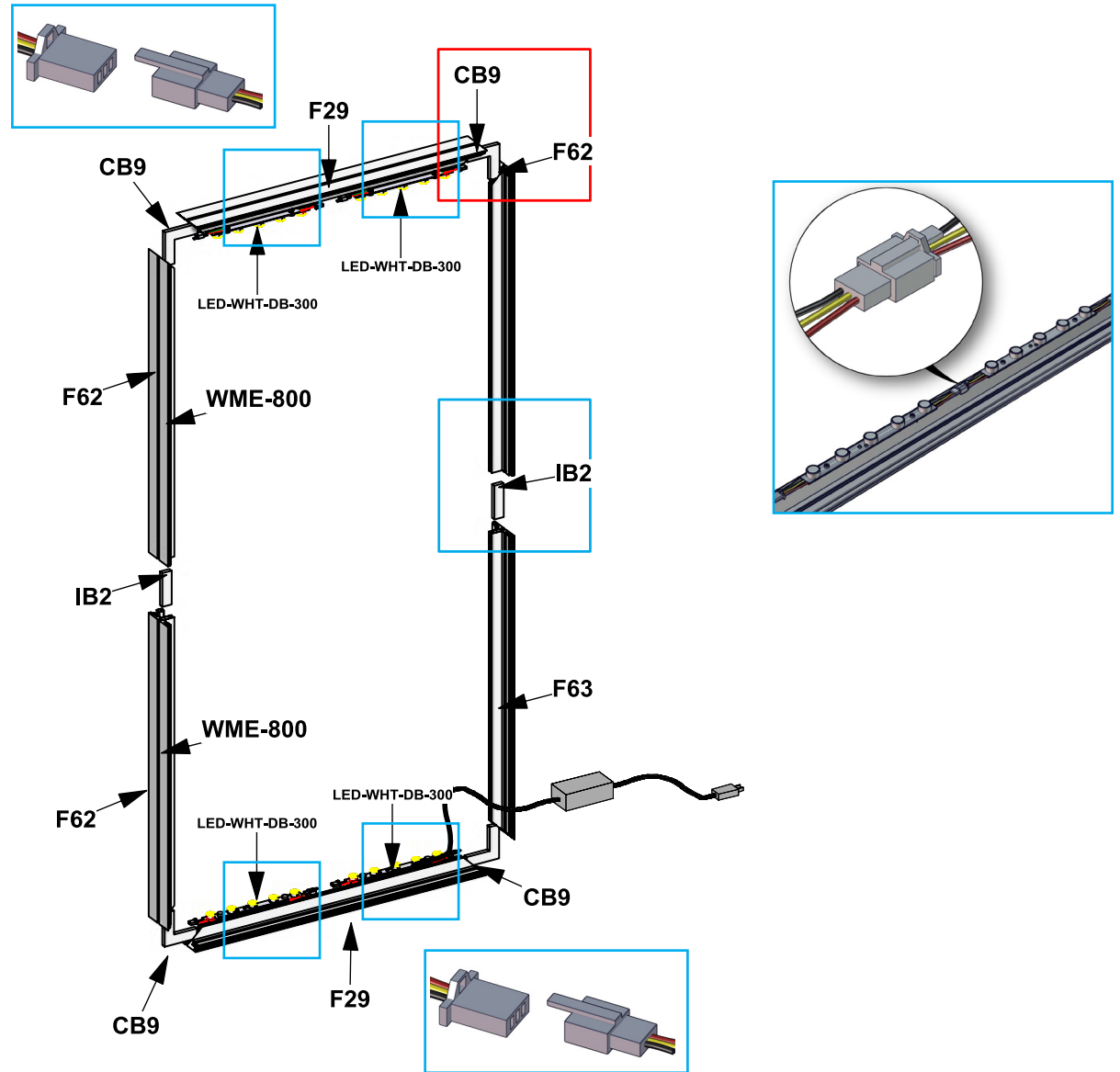
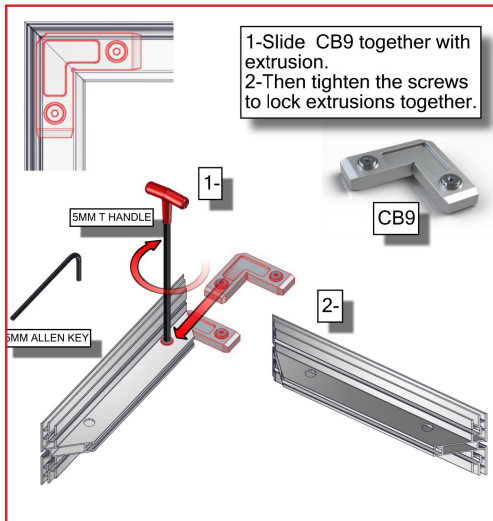
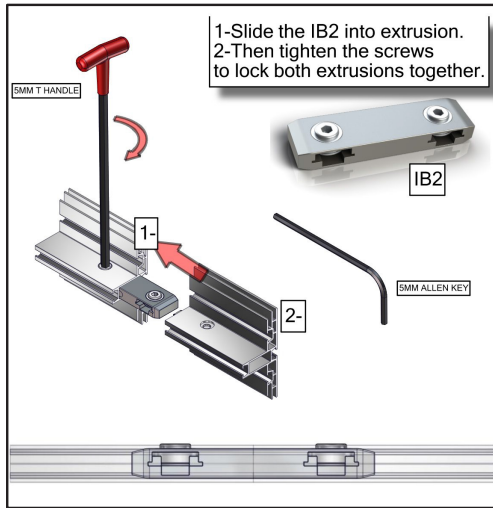

## Step 2: Attach Light Strips with Wire Management

Once frame is assembled and lighting strips are connected, connect black wire LED-DB-LC-2400 to lighting strips on top and bottom. Run cords with wire management extrusion (WME). Place LED-DB-LC-2400 into plastic wire management strip and insert into F62 extrusion. Next, run LED-DB-CL-DCJ-600 cord through wire hole at the bottom right end of vertical extrusion then connect to lighting strip. Connect to power supply. Important: 9 lighting strips maximum per power supply.

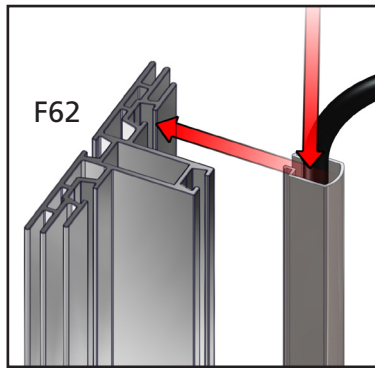
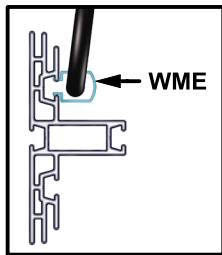
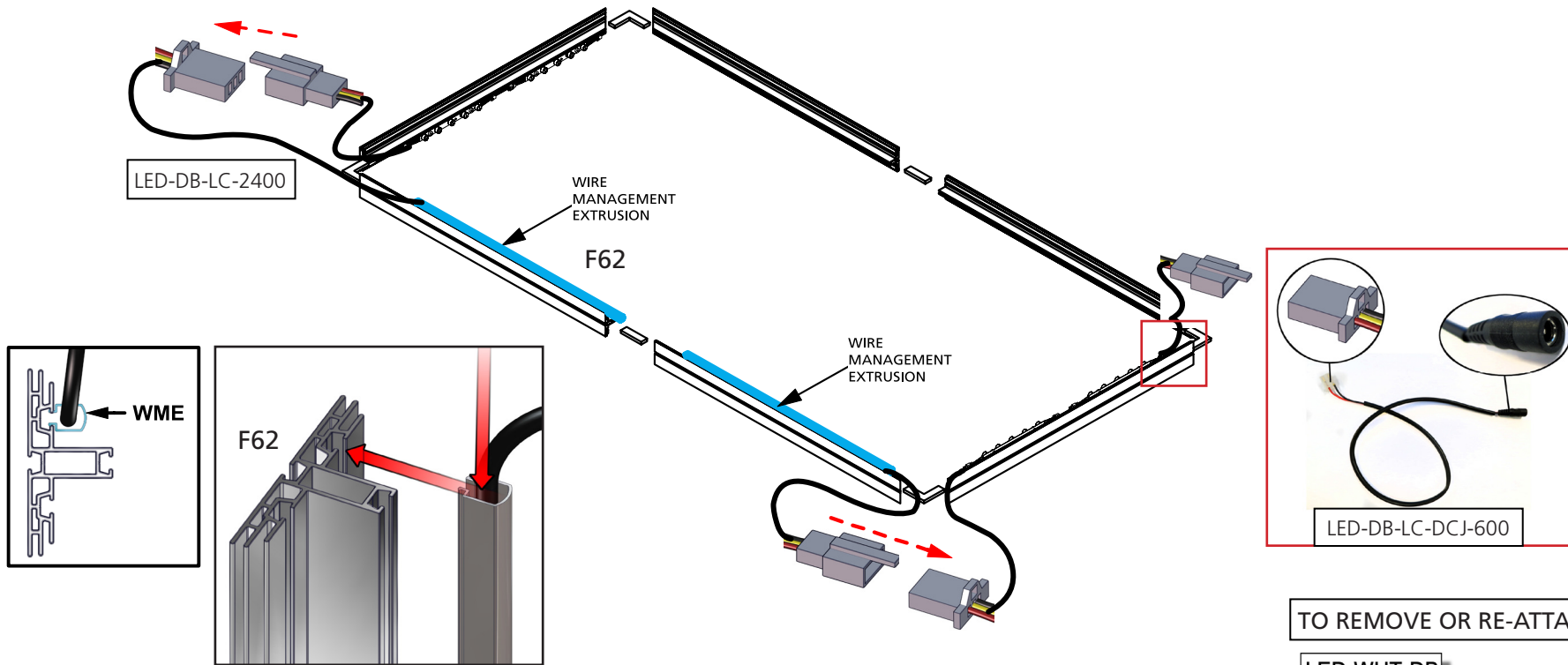

### TO REMOVE OR RE-ATTACH LIGHTS:

#### LED-WHT-DB

1- ATTACH LED LIGHTING STRIP WITH THUMBSCREWS

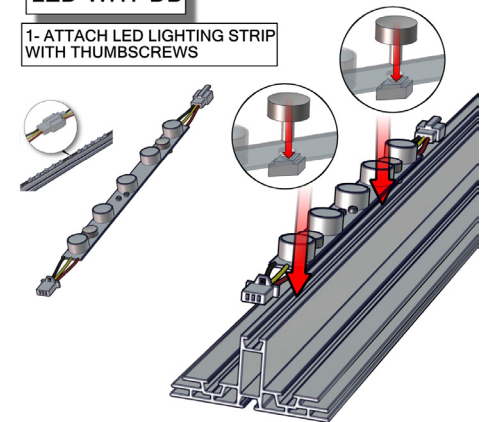

### CONNECT TO POWER SUPPLY:



### Step 3: Attach feet to frame & apply graphics

To adhere foot to frame, loosen thumbscrews from foot. Slide extrusion into LN-100 groove. Gently tighten the foot into place. Install graphics by pressing the FCE-2 edge of graphic into the channel of the extrusion. Printed fabric graphic should be placed in outside channel(s). Liner for single-sided light boxes is placed in inside channel. Start in upper left corner, go across the top and then down the sides to the bottom. Assure each graphic is tightly inserted. When taking graphics off, take care to gently pull by attached pull tab. Set frame aside.

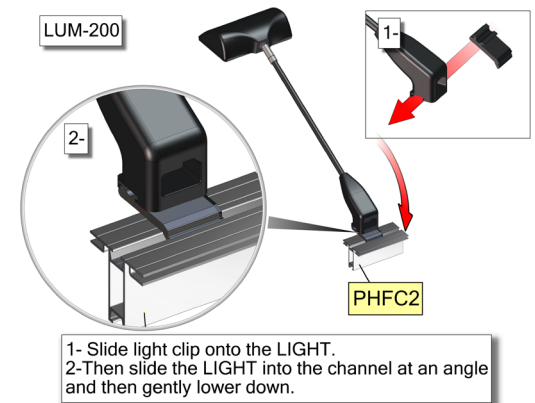
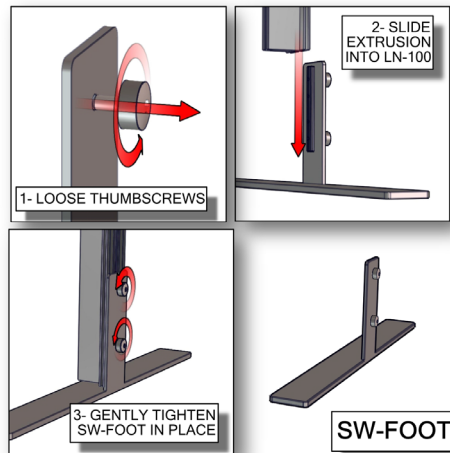
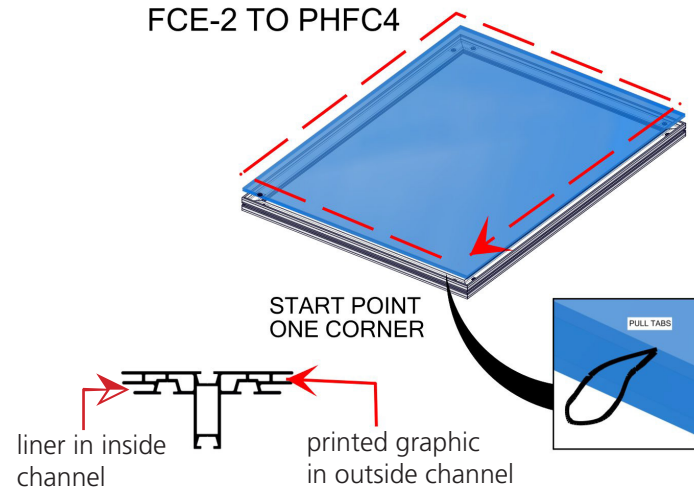
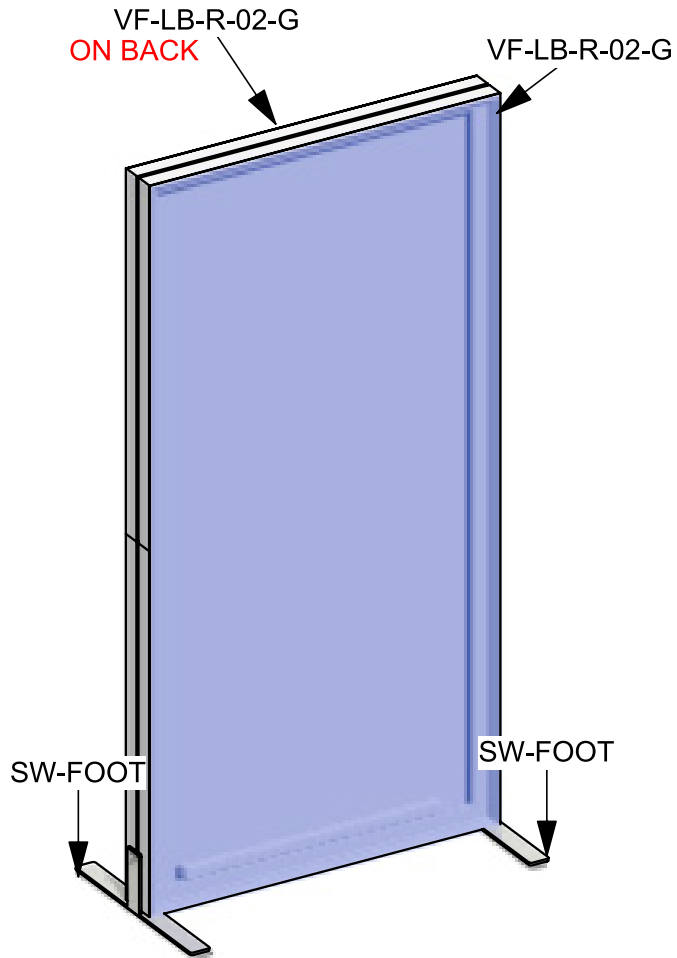

**OPTIONAL**

# Vector Frame Banners and Light Boxes

## Banners:



Vector Frame Banner  
VF-R-01

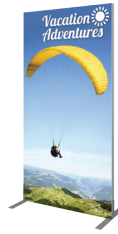

Vector Frame Banner  
VF-R-02



Vector Frame Banner  
VF-R-03



Vector Frame Banner  
VF-R-04



Vector Frame Banner  
VF-R-05



Vector Frame Banner  
VF-S-01



Vector Frame Banner  
VF-S-02



Vector Frame Banner  
VF-S-03



Vector Frame Banner  
VF-S-04

## Lightboxes:



Vector Frame Lightbox  
VF-LF-R-01



Vector Frame Lightbox  
VF-LB-R-02



Vector Frame Lightbox  
VF-LB-R-03



Vector Frame Lightbox  
VF-LB-R-04



Vector Frame Lightbox  
VF-LB-R-05



Vector Frame Lightbox  
VF-LB-S-01



Vector Frame Lightbox  
VF-LB-S-02



Vector Frame Lightbox  
VF-LB-S-03

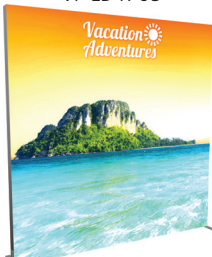

Vector Frame Lightbox  
VF-LB-S-04