

Modulate Frame 13

MOD-FRM-13

Modulate™ Fabric Banners feature unique angles and shapes, are portable and easy to assemble. Choose from multiple frame shapes and connect them to design your own combinations. The aluminum tube frames feature snap-button and spigot connections and are coupled with a printed pillowcase fabric graphic that slips over the frame and zips at the bottom. Two linking clips are included to connect banner frames together and universal feet connect the tube frames at the bottom of the display. Each frame comes in a durable, portable carry bag.

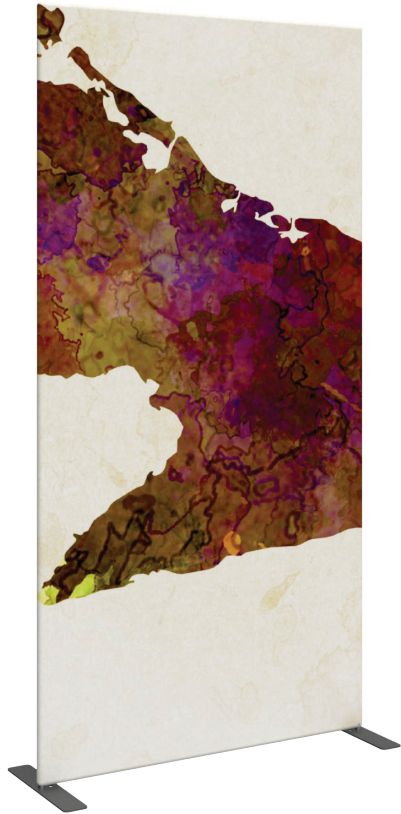

features and benefits:

- Premium aluminum tube frame with spigot and snap button assembly
- Easy to store and ship
- Quick to set up
- Weighted feet for added stability
- Comes with carry bag and box
- Zipper pillowcase fabric graphics
- Lifetime limited hardware warranty against manufacturer defects

dimensions:

Hardware	Graphic
<p>Assembled unit: 48.74" w x 96" h x 17.72" d 1238mm(w) x 2438mm(h) x 450mm(d)</p> <p>Approximate weight: 10 lb / 5 kg</p>	<p>Refer to related graphic template for more information.</p> <p>Visit: www.exhibitors-handbook.com/graphic-templates</p>
Shipping	additional information:
<p>Packing box(es): 1 Box</p> <p>Box size: 48" l x 11" h x 4" d 1219mm(l) x 279mm(h) x 102mm(d)</p> <p>Approximate shipping weight: 12 lb / 6 kg</p>	<p>Graphic material: Dye-sublimation zipper pillowcase fabric</p> <p>When included in a larger kit, a different packaging solution will be listed to accommodate all contents of the kit. Individual packaging no longer provided.</p>

We are continually improving and modifying our product range and reserve the right to vary the specifications without prior notice. All dimensions and weights quoted are approximate and we accept no responsibility for variance. E&OE. See Graphic Templates for graphic bleed specifications.

Included In Your Kit

Tools, Components, Connectors, Tubes & Graphics



HEX KEY SET x1

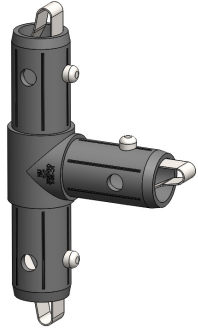

TC-30-T x2

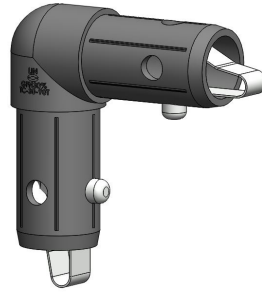

TC-30-90T x2

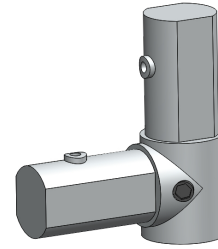

ES30-90B x2

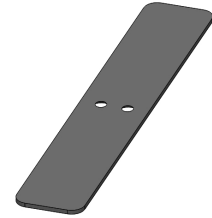

PLT-BP-LN114-S5-450 x2

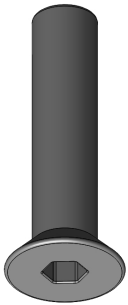

LN114-SCRW x2



MOD-FRM-13-T2 x3



MOD-FRM-13-T1 x4



MOD-CLP-180 x2



MOD-FRM-13-G x1

Exploded View

MOD-FRM-13

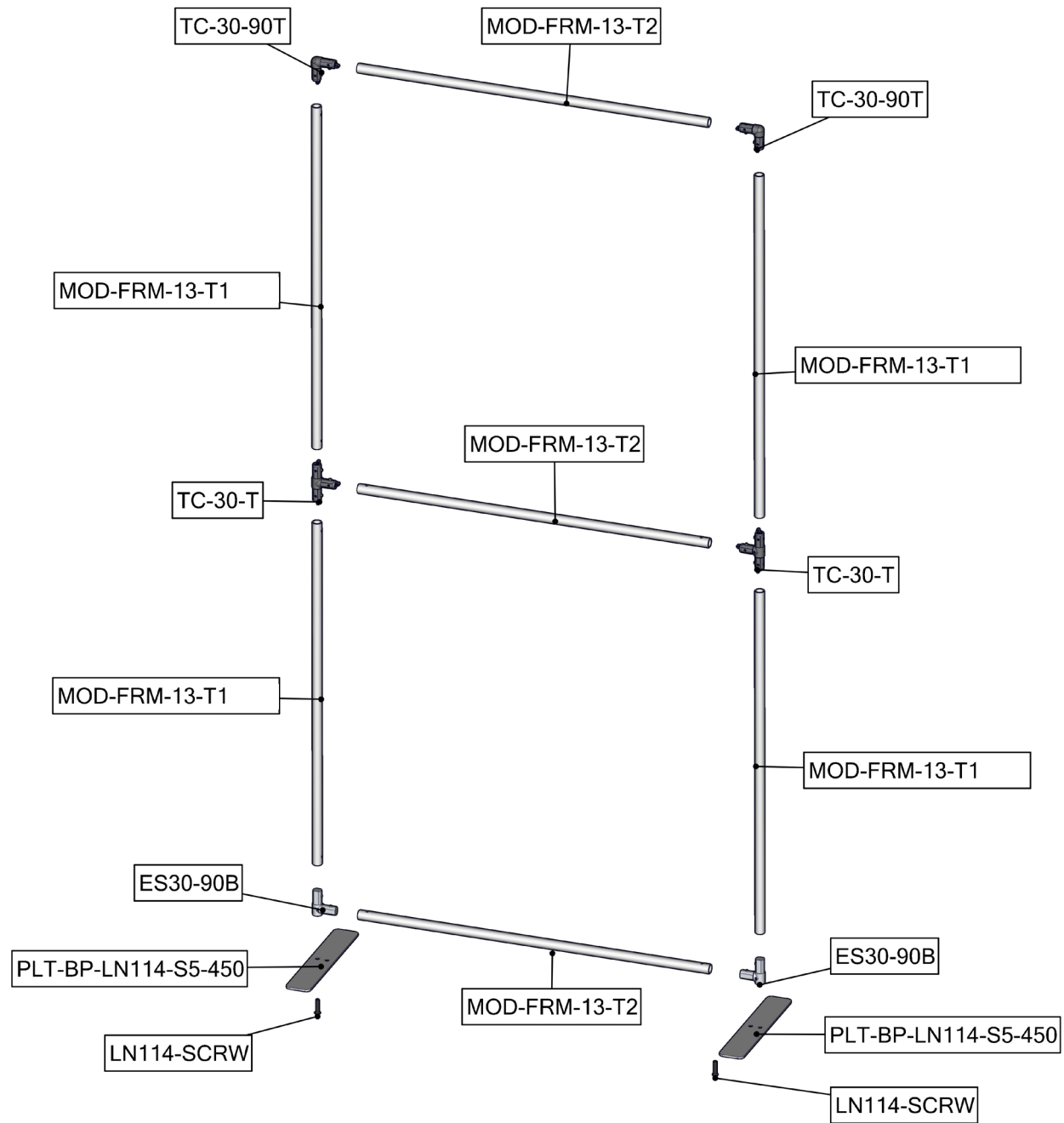

Labeling Diagram

MOD-FRM-13

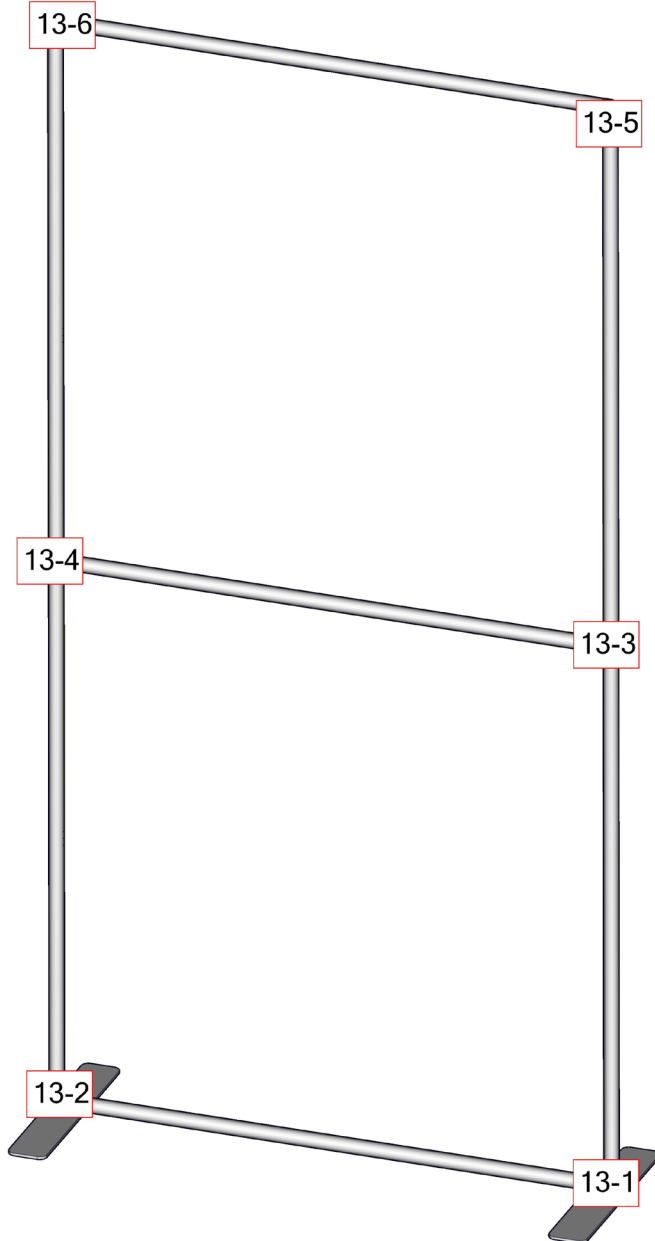

Connection Methods

Connection Method 1: TC-30-T

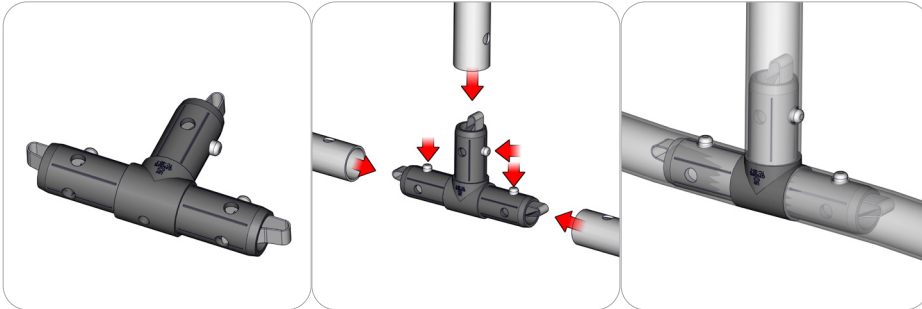

Take the plastic connector and make sure the snap buttons are in proper position for the frame tube holes. Simply press the snap button with your thumb and carefully slide the tube onto the connector. The snap button should pop through. Some twisting may be necessary to assure the snap button has popped all the way through the tube hole. Do not force the connection and be careful with the tube edges, they may be sharp.

Connection Method 2: TC-30-90T

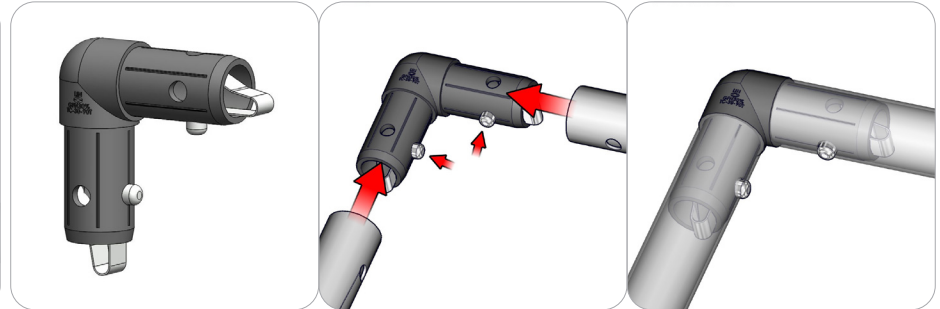

Take the plastic connector and make sure the snap buttons are in proper position for the frame tube holes. Simply press the snap button with your thumb and carefully slide the tube onto the connector. The snap button should pop through. Some twisting may be necessary to assure the snap button has popped all the way through the tube hole. Do not force the connection and be careful with the tube edges, they may be sharp.

Connection Method 3: TC-30-X

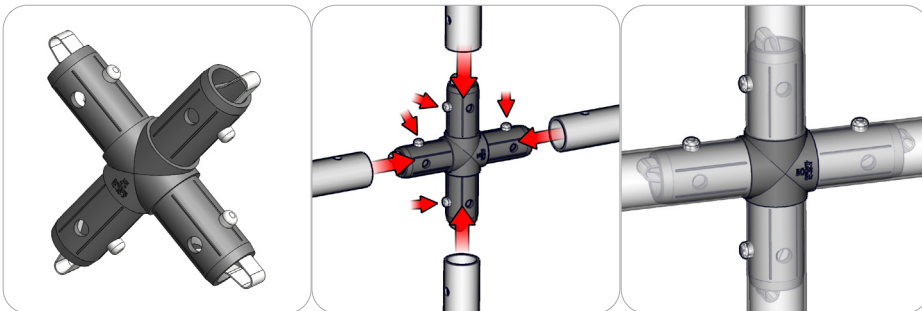

Take the plastic connector and make sure the snap buttons are in proper position for the frame tube holes. Simply press the snap button with your thumb and carefully slide the tube onto the connector. The snap button should pop through. Some twisting may be necessary to assure the snap button has popped all the way through the tube hole. Do not force the connection and be careful with the tube edges, they may be sharp.

Connection Method 4: TC-30-T-CS

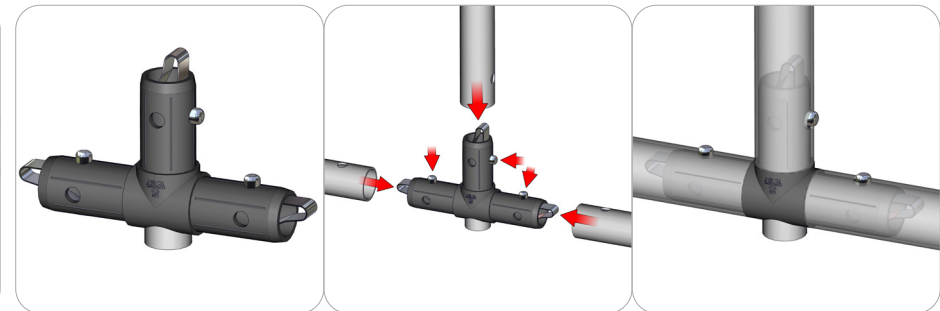

Take the plastic connector and make sure the snap buttons are in proper position for the frame tube holes. Simply press the snap button with your thumb and carefully slide the tube onto the connector. The snap button should pop through. Some twisting may be necessary to assure the snap button has popped all the way through the tube hole. Do not force the connection and be careful with the tube edges, they may be sharp.

Connection Methods

Connection Method 5: ES30-90B

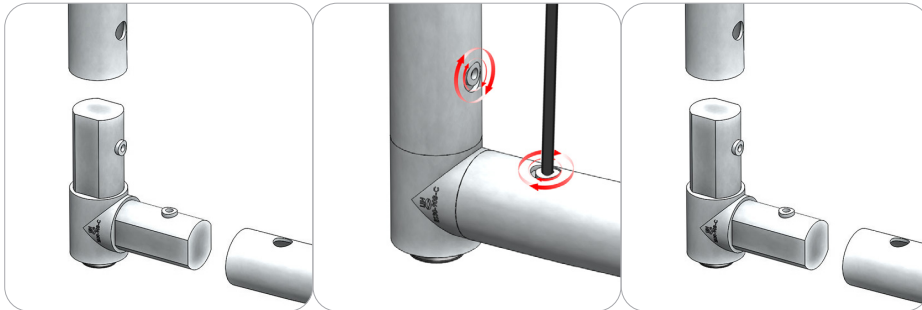

Compress one unlocked end of the connector and slide it through one tube end. Compress the other end of the connector and slide the second tube on. Lock both screws carefully using your allen key tool. Be sure to lock securely, but do not over tighten.

Connection Method 6: PLT-BP-LN114-S5

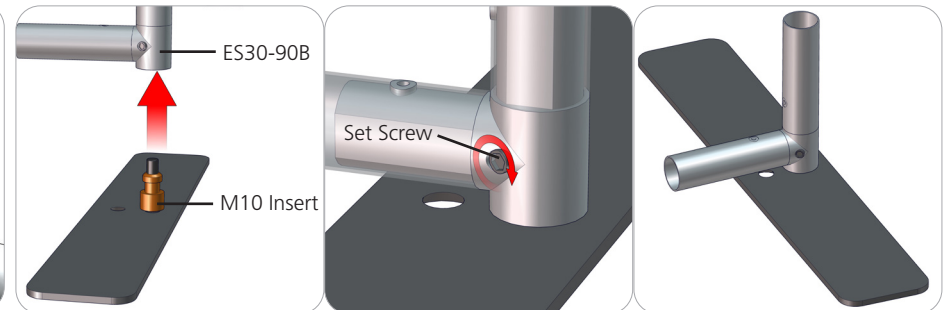

First, loosen the set screw that is on the ES30-90B, then attach the base plate with the M10 insert. Once the base plate is in the desired position, fasten the set screw to hold the insert in place.

Connection Method 7: PLT-BP-LN114-S5

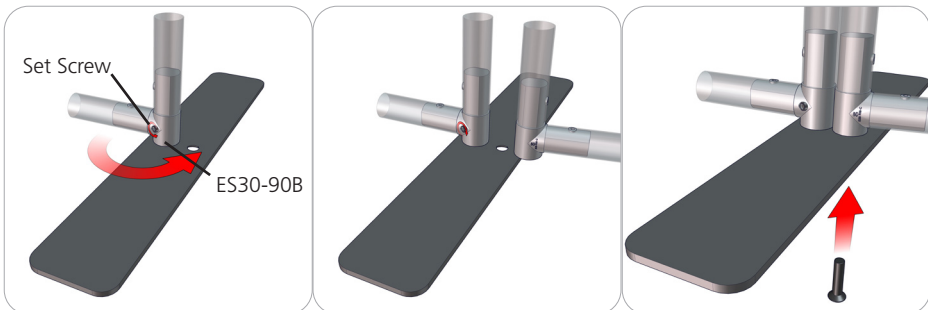

To attach two frames side by side loosen the set screw that is on the ES30-90B. Do not remove the set screw. Next, rotate the stabilizing base hole to the outside of the frame and tighten the set screw. Next, use the provided ES30-90B M10 bolt to fasten the frame onto the base. Don't forget to use your frame clip at the top to level the panels.

Connection Method 8: MOD-CLP

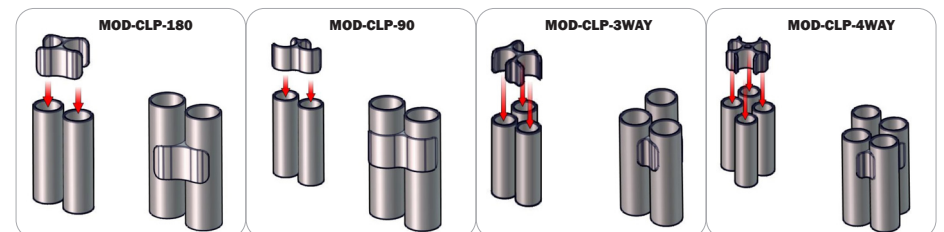

Be sure to fully assemble all frames with fabric pillowcase before using clips. Simply snap the frames into the clips and adjust until frames are aligned as desired.

Kit Assembly

Step by Step

Step 1.

Gather the components to build the frame. Use the Exploded View and the Labeling Diagram for part labels.

Reference Connection Method(s) 1, 2 and 5 for more details.

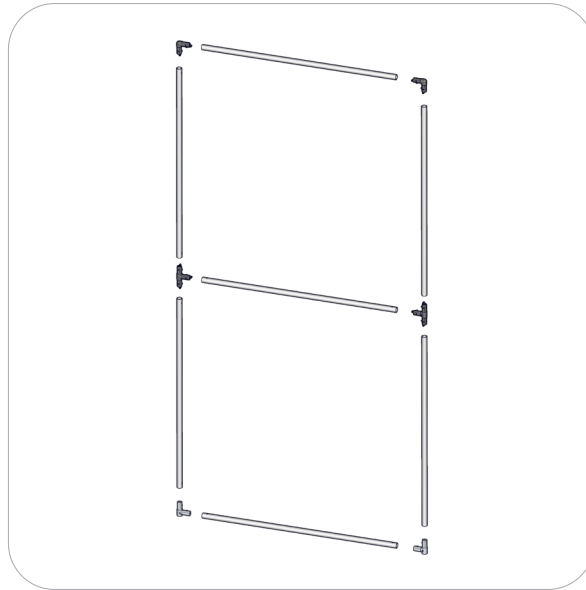
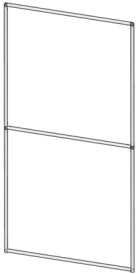

Step 2.

Locate your pillowcase graphic. With the pillowcase unzipped, encase the frame by covering the frame from top to bottom. Zipper at the bottom.

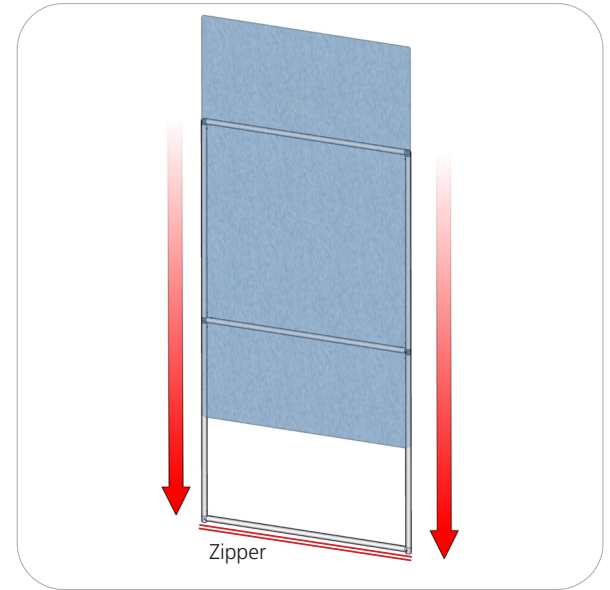

Step 3.

Locate the stabilizing bases. Attach each foot to the bottom ends of the frame. Use the allen key tool provided to lock the bases in place.

Reference Connection Method(s) 6 for more details.

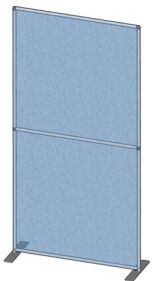

Step 4.

Setup is complete.

If you are connecting frames side by side, reference Connection Method(s) 7 and 8 for more details.

