

LIGHTBOX DISPLAYS

GLM SELECT - 80 MM DOUBLE-SIDED
LIGHTBOX DISPLAY
PRODUCT CODE: OC-LIGHTBOXG2

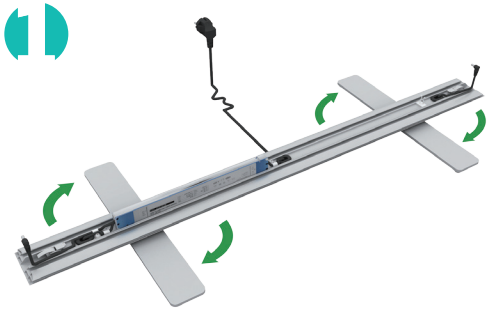

INSTRUCTIONS



- See numbers on each extrusion piece. Match number together (e.g. 3-3). From the bottom extrusion, twist the feet.

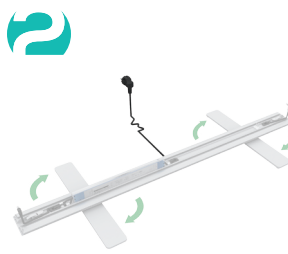

- Connect the transformer power cords together. Then tighten the knob to secure the cords.

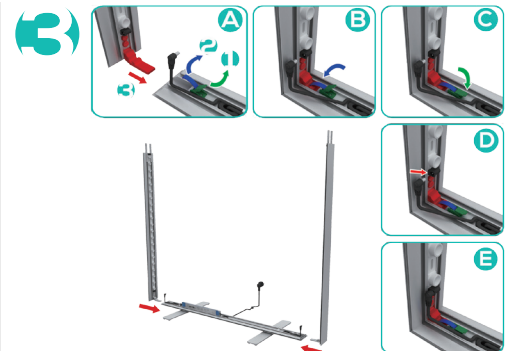

- Slide side extrusions into bottom extrusion channel. Use latch to press down on the L connector. Then press down the second latch to secure. Connect LED strip cable to LED edge light connectors.

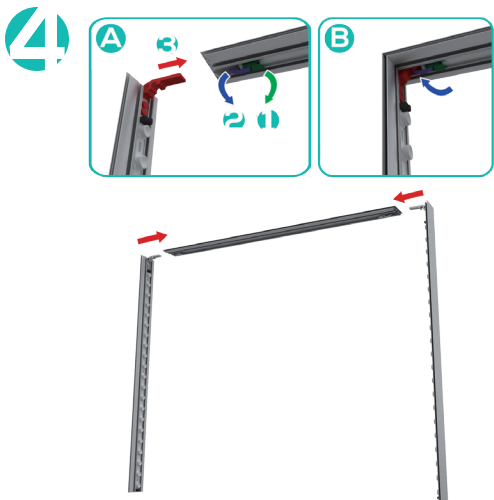

- Slide side extrusions into top extrusion channel. Use latch to press down on the L connector. Then press down the second latch to secure.

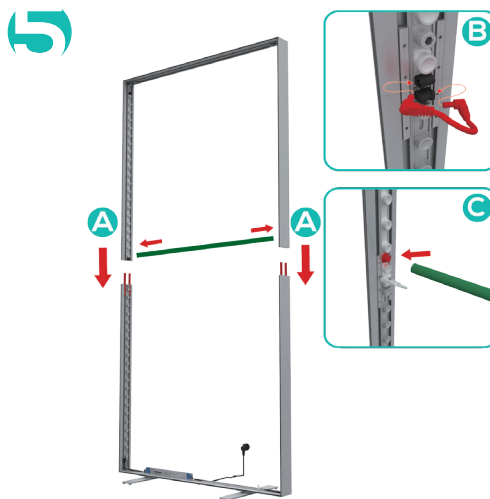

- Place the top half of the extrusion and slide onto the split connector of the bottom half extrusion. Connect LED Wire Connector to LED strips. Install Support Pole on each side of the inner frame.



- In each corner, insert the silicone edge beading into the groove of the frame. Then insert the the remainder of the beading on each side.

NOTE: Instructions can be seen on the Light Box case.